

KLT-X2MF-OX02A10 V1.0**OmniVision OX02A10 MIPI Interface Foco Fixo 1MP M12 Módulo de Câmera**

Módulo de câmara No.	KLT-X2MF-OX02A10 V1.0
Sensor de imagem	OX02A10
EFL	3.47 mm
F.NO	2.2
Pixel	1824 x 940
Ângulo de visão	157°(D) 133°(H) 72°(V)
Tipo de lente	1/2.09 polegada
Dimensões da lente	14.00 X 14.00 X 20.31 mm
Tamanho do Módulo	40.00 x 24.00 mm
Tipo de Módulo	Foco Fixo
Interface	MIPI

Acasalamento Parte conector No. DF30FC-30DS-0.4V

Conector de acoplamento na placa principal. Vendido separadamente.

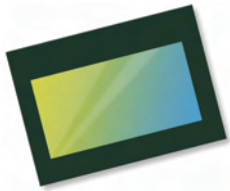

OX02A10 1.7MP product brief



High Dynamic Range and LED Flicker Reduction for Display-Based Automotive Vision Systems



OmniVision's OX02A10 is a high-performance image sensor that is designed for the next-generation display-based camera monitoring systems for automotive applications. Built on OmniVision's 4.2-micron OmniBSI™ split-pixel technology for exceptional high dynamic range (HDR), the OX02A10 offers best-in-class low-light performance and represents the automotive industry's leading LED flicker-reduction solution.

The OX02A10 achieves 110 dB HDR while guaranteeing LED pulse capture. This allows the automotive cameras to simultaneously capture bright and dark scenes, providing excellent performance in the most demanding

lighting conditions. The OX02A10 supports 1820 x 940 resolution in a 1:2 aspect ratio at 60 frames per second (fps), making it ideally suited for wider aspect ratio e-Mirror applications.

Additionally, the sensor's on-chip combination algorithm reduces the output data rate for easier data transition and back-end processing. The OX02A10 comes in a 9.5 x 6.8 mm AEC Q-100 Grade 2 qualified automotive chip-scale package (a-CSP™).

Find out more at www.ovt.com.



Applications

- Automotive
 - 360° Surround View System
 - Rear View Camera
 - Lane Departure Warning/ Lane Keep Assist
 - Blind Spot Detection
 - Night Vision
- Pedestrian Detection
- Traffic Sign Recognition
- Camera Monitoring System
- Autonomous Driving
- e-Mirror

Product Features

- support for image size:
 - 1824 x 940
 - VGA
 - QVGA and any cropped size
- OmniHDR-S™ technology
- high sensitivity
- safety features
- low power consumption
- image sensor processor functions:
 - lens correction
 - defective pixel cancelation
 - HDR combination and tone mapping
 - automatic black level correction
- supported output formats: RAW
- horizontal and vertical sub-sampling
- serial camera control bus (SCCB) for register programming
- high speed serial data transfer with MIPI CSI-2, parallel 12-bit DVP output
- external frame synchronization capability
- embedded temperature sensor
- one time programmable (OTP) memory
- support for LED flicker reduction (LFR) function

OX02A10



Ordering Information

- OX02A10-E85Y-PA-Z**
(color, lead-free) 85-pin a-CSP™ with dual coated AR glass, packed in tray with protective film
- OX02A10-E85Y-RA-Z**
(color, lead-free) 85-pin a-CSP™ with dual coated AR glass, packed in tape & reel with protective film

Product Specifications

- active array size:** 1824 x 940
- power supply:**
 - analog: 3.14 - 3.47V
 - digital: 1.425 - 1.575V
 - DVDD: 1.7 - 1.9V
 - AVDD: 1.7 - 1.9V
- power requirements:**
 - active: 450 mW
 - standby: 100 µW
- temperature:**
 - operating: -40°C to +105°C sensor ambient temperature and -40°C to +125°C junction temperature
- output interfaces:** 12-bit DVP, MIPI CSI-2
- input clock frequency:** 6 - 36 MHz
- lens size:** 1/2.09"
- lens chief ray angle:** 19°
- output formats:**
 - 20-bit combined RAW
 - 12-bit compressed combined RAW
 - separated 12-bit RAW
 - 2x12 bit compressed RAW
 - 16-bit log domain combined RAW
- scan mode:** progressive
- shutter:** rolling shutter
- maximum image transfer rate:** 60 fps
- sensitivity:** 8.5 V/Lux-sec
- max S/N ratio:** 41.7 dB
- dynamic range:** 110 dB
- pixel size:** 4.2 µm x 4.2 µm
- image area:** 7711.2 µm x 3998.4 µm
- package dimensions:** 9510 µm x 6860 µm

Functional Block Diagram

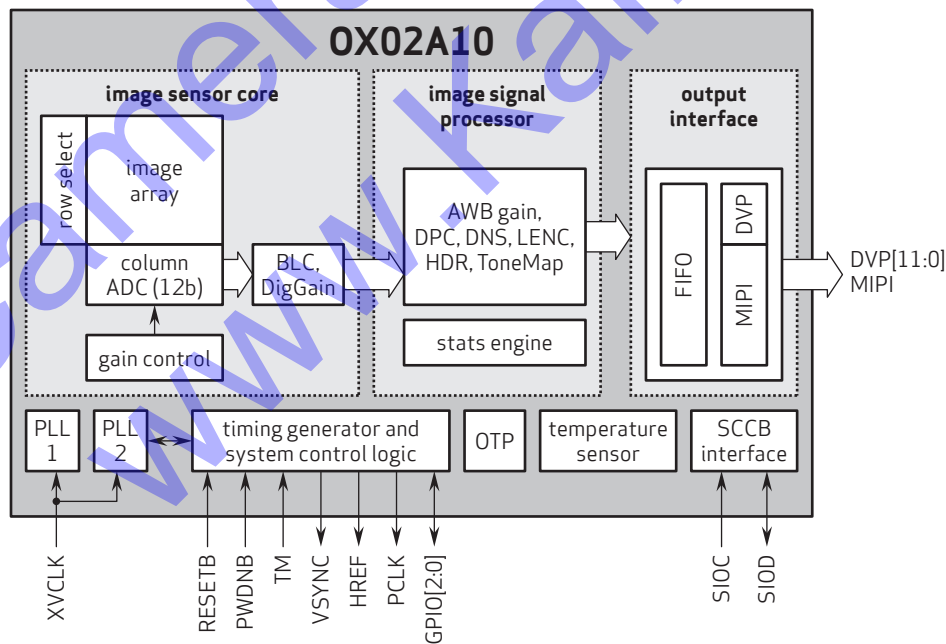

4275 Burton Drive
Santa Clara, CA 95054
USA

Tel: + 1 408 567 3000
Fax: + 1 408 567 3001
www.ovt.com

OmniVision reserves the right to make changes to their products or to discontinue any product or service without further notice. OmniVision and the OmniVision logo are registered trademarks of OmniVision Technologies, Inc. OmniBSI, a-CSP, and OmniHDR-S are trademarks of OmniVision Technologies, Inc. All other trademarks used herein are the property of their respective owners.



OmniVision